

Transient Voltage Suppressors (TVS) Data Sheet

Features

- Glass passivated junction
- Low zener impedance
- Excellent clamping capability
- 1000W peak pulse power capability at 10/1000µs waveform, repetition rate (duty cycle):0.01%
- Fast response time
- Typical I_R less than 1µA above 11V.
- Plastic package has underwriters laboratory flammability 94V-0
- Meets MSL level 1, per J-STD-020.

Mechanical Data

- Case: JEDEC DO-214AA Moulded plastic
- Terminal: solderplated, solderable per MIL-STD-750, Method 2026
- Polarity: Color band denotes cathode except bi-directional models
- Mounting Position: Any

Applications

- I/O interface
- AC/DC power supply
- Low frequency signal transmission line (RS232, RS485, etc.)

Maximum Ratings and Characteristics

Ratings at 25°C ambient temperature unless otherwise specified.

Rating	Symbol	Value	Units
Peak pulse power dissipation at 10/1000µs waveform (Note1, Fig.1)	P_{PPM}	Minimum 1000	Watts
Peak pulse current of at 10/1000µs waveform (Note 1, Fig.3)	I_{PPM}	See Table	Amps
Steady state power dissipation at $T_L=75^\circ\text{C}$ (Fig.4)	$P_{M(AV)}$	5	Watts
Peak forward surge current, 8.3ms single half sine-wave superimposed on rated load, (JEDEC Method) (Note2)	I_{FSM}	120	Amps
Operating junction and Storage Temperature Range.	T_J, T_{STG}	-55 to +150	°C
Typical thermal resistance junction to lead	$R_{\theta JL}$	20	°C/W
Typical thermal resistance junction to ambient	$R_{\theta JA}$	100	°C/W

Notes: 1. Non-repetitive current pulse, per Fig.3 and derated above $T_A=25^\circ\text{C}$ per Fig.2.

2. 8.3ms single half sine-wave, or equivalent square wave, duty cycle=4 pulses per minutes maximum.

Dimensions (DO-214AA/SMB)

Symbol	Millimeters		Inches	
	Min.	Max.	Min.	Max.
L	4.06	4.75	0.160	0.187
D	3.30	3.94	0.130	0.155
D1	1.95	2.20	0.077	0.086
T	5.18	5.59	0.204	0.220
T1	0.76	1.52	0.030	0.060
d	-	0.203	-	0.008
H	1.99	2.61	0.078	0.103

Electrical Characteristics (TA=25°C)

Part Number		Device Marking Code		Reverse Stand-Off Voltage	Breakdown Voltage @I _T	Test Current	Maximum Clamping Voltage @I _{PP}	Peak Pulse Current	Reverse Leakage @V _{RWM}
Unidirectional	Bidirectional	UNI	BI	V _{RWM} (V)	V _{BR} (V)	I _T (mA)	V _C (V)	I _{PP} (A)	I _R (μA)
1.0SMBJ5.0A	1.0SMBJ5.0CA	1.0KE	1.0AE	5.0	6.4~7.0	10	9.2	108.7	800
1.0SMBJ6.0A	1.0SMBJ6.0CA	1.0KG	1.0AG	6.0	6.7~7.4	10	10.3	97.1	800
1.0SMBJ6.5A	1.0SMBJ6.5CA	1.0KK	1.0AK	6.5	7.2~8.0	10	11.2	89.3	500
1.0SMBJ7.0A	1.0SMBJ7.0CA	1.0KM	1.0AM	7.0	7.8~8.6	10	12.0	83.3	200
1.0SMBJ7.5A	1.0SMBJ7.5CA	1.0KP	1.0AP	7.5	8.3~9.2	1	12.9	77.5	100
1.0SMBJ8.0A	1.0SMBJ8.0CA	1.0KR	1.0AR	8.0	8.9~9.8	1	13.6	73.5	50
1.0SMBJ8.5A	1.0SMBJ8.5CA	1.0KT	1.0AA	8.5	9.4~10.4	1	14.4	69.4	20
1.0SMBJ9.0A	1.0SMBJ9.0CA	1.0KV	1.0AV	9.0	10.0~11.0	1	15.4	64.9	10
1.0SMBJ10A	1.0SMBJ10CA	1.0KX	1.0AX	10.0	11.1~12.3	1	17.0	58.8	5
1.0SMBJ11A	1.0SMBJ11CA	1.0KZ	1.0AZ	11.0	12.2~13.5	1	18.2	54.9	1
1.0SMBJ12A	1.0SMBJ12CA	1.0LE	1.0BE	12.0	13.3~14.7	1	19.9	50.3	1
1.0SMBJ13A	1.0SMBJ13CA	1.0LG	1.0BG	13.0	14.4~15.9	1	21.5	46.5	1
1.0SMBJ14A	1.0SMBJ14CA	1.0LK	1.0BK	14.0	15.6~17.2	1	23.2	43.1	1
1.0SMBJ15A	1.0SMBJ15CA	1.0LM	1.0BM	15.0	16.7~18.5	1	24.4	41.0	1
1.0SMBJ16A	1.0SMBJ16CA	1.0LP	1.0BP	16.0	17.8~19.7	1	26.0	38.5	1
1.0SMBJ17A	1.0SMBJ17CA	1.0LR	1.0BR	17.0	18.9~20.9	1	27.6	36.2	1
1.0SMBJ18A	1.0SMBJ18CA	1.0LT	1.0BT	18.0	20.0~22.1	1	29.2	34.2	1
1.0SMBJ19A	1.0SMBJ19CA	1.0LW	1.0BW	19.0	21.1~23.3	1	30.8	32.5	1
1.0SMBJ20A	1.0SMBJ20CA	1.0LV	1.0BV	20.0	22.2~24.5	1	32.4	30.9	1
1.0SMBJ22A	1.0SMBJ22CA	1.0LX	1.0BX	22.0	24.4~26.9	1	35.5	28.2	1
1.0SMBJ24A	1.0SMBJ24CA	1.0LZ	1.0BZ	24.0	26.7~29.5	1	38.9	25.7	1
1.0SMBJ26A	1.0SMBJ26CA	1.0ME	1.0CE	26.0	28.9~31.9	1	42.1	23.8	1

Electrical Characteristics (TA=25°C)

Part Number		Device Marking Code		Reverse Stand-Off Voltage	Breakdown Voltage @IT	Test Current	Maximum Clamping Voltage @ I _{PP}	Peak Pulse Current	Reverse Leakage @ V _{RWM}
Unidirectional	Bidirectional	UNI	BI	V _{RWM} (V)	V _{BR} (V)	I _T (mA)	V _C (V)	I _{PP} (A)	I _R (μA)
1.0SMBJ28A	1.0SMBJ28CA	1.0MG	1.0CG	28.0	31.1~34.4	1	45.4	22.0	1
1.0SMBJ30A	1.0SMBJ30CA	1.0MK	1.0CK	30.0	33.3~36.8	1	48.4	20.7	1
1.0SMBJ33A	1.0SMBJ33CA	1.0MM	1.0CM	33.0	36.7~40.6	1	53.3	18.8	1
1.0SMBJ36A	1.0SMBJ36CA	1.0MP	1.0CP	36.0	40.0~44.2	1	58.1	17.2	1
1.0SMBJ40A	1.0SMBJ40CA	1.0MR	1.0CR	40.0	44.4~49.1	1	64.5	15.5	1
1.0SMBJ43A	1.0SMBJ43CA	1.0MT	1.0CT	43.0	47.8~52.8	1	69.4	14.4	1
1.0SMBJ45A	1.0SMBJ45CA	1.0MV	1.0CV	45.0	50.0~55.3	1	72.7	13.8	1
1.0SMBJ48A	1.0SMBJ48CA	1.0MX	1.0CX	48.0	53.3~58.9	1	77.4	12.9	1
1.0SMBJ51A	1.0SMBJ51CA	1.0MZ	1.0CZ	51.0	56.7~62.7	1	82.4	12.1	1
1.0SMBJ54A	1.0SMBJ54CA	1.0NE	1.0DE	54.0	60.0~66.3	1	87.1	11.5	1
1.0SMBJ58A	1.0SMBJ58CA	1.0NG	1.0DG	58.0	64.4~71.2	1	93.6	10.7	1
1.0SMBJ60A	1.0SMBJ60CA	1.0NK	1.0DK	60.0	66.7~73.7	1	96.8	10.3	1
1.0SMBJ64A	1.0SMBJ64CA	1.0NM	1.0DM	64.0	71.1~78.6	1	103.0	9.7	1
1.0SMBJ70A	1.0SMBJ70CA	1.0NP	1.0DP	70.0	77.8~86.0	1	113.0	8.8	1
1.0SMBJ75A	1.0SMBJ75CA	1.0NR	1.0DR	75.0	83.3~92.1	1	121.0	8.3	1
1.0SMBJ78A	1.0SMBJ78CA	1.0NT	1.0DT	78.0	86.7~95.8	1	126.0	7.9	1
1.0SMBJ80A	1.0SMBJ80CA	1.0NW	1.0DW	80.0	88.8~97.6	1	129.6	7.7	1
1.0SMBJ85A	1.0SMBJ85CA	1.0NV	1.0DV	85.0	94.4~104	1	137.0	7.3	1
1.0SMBJ90A	1.0SMBJ90CA	1.0NX	1.0DX	90.0	100~111	1	146.0	6.8	1
1.0SMBJ100A	1.0SMBJ100CA	1.0NZ	1.0DZ	100.0	111~123	1	162.0	6.2	1
1.0SMBJ110A	1.0SMBJ110CA	1.0PE	1.0EE	110.0	122~135	1	177.0	5.6	1
1.0SMBJ120A	1.0SMBJ120CA	1.0PG	1.0EG	120.0	133~147	1	193.0	5.2	1
1.0SMBJ130A	1.0SMBJ130CA	1.0PK	1.0EK	130.0	144~159	1	209.0	4.8	1
1.0SMBJ140A	1.0SMBJ140CA	1.0PL	1.0EL	140.0	155~171	1	227.0	4.4	1
1.0SMBJ150A	1.0SMBJ150CA	1.0PM	1.0EM	150.0	167~185	1	243.0	4.1	1
1.0SMBJ160A	1.0SMBJ160CA	1.0PP	1.0EP	160.0	178~197	1	259.0	3.9	1
1.0SMBJ170A	1.0SMBJ170CA	1.0PR	1.0ER	170.0	189~209	1	275.0	3.6	1
1.0SMBJ180A	1.0SMBJ180CA	1.0ET	1.0PT	180.0	200~220	1	291.0	3.4	1
1.0SMBJ190A	1.0SMBJ190CA	1.0EU	1.0PU	190.0	211~232	1	308.0	3.2	1
1.0SMBJ200A	1.0SMBJ200CA	1.0EV	1.0PV	200.0	224~247	1	324.0	3.0	1

Notes: For bidirectional type having VRWM of 10V and less, the IR limit is double.

Recommended Soldering Conditions

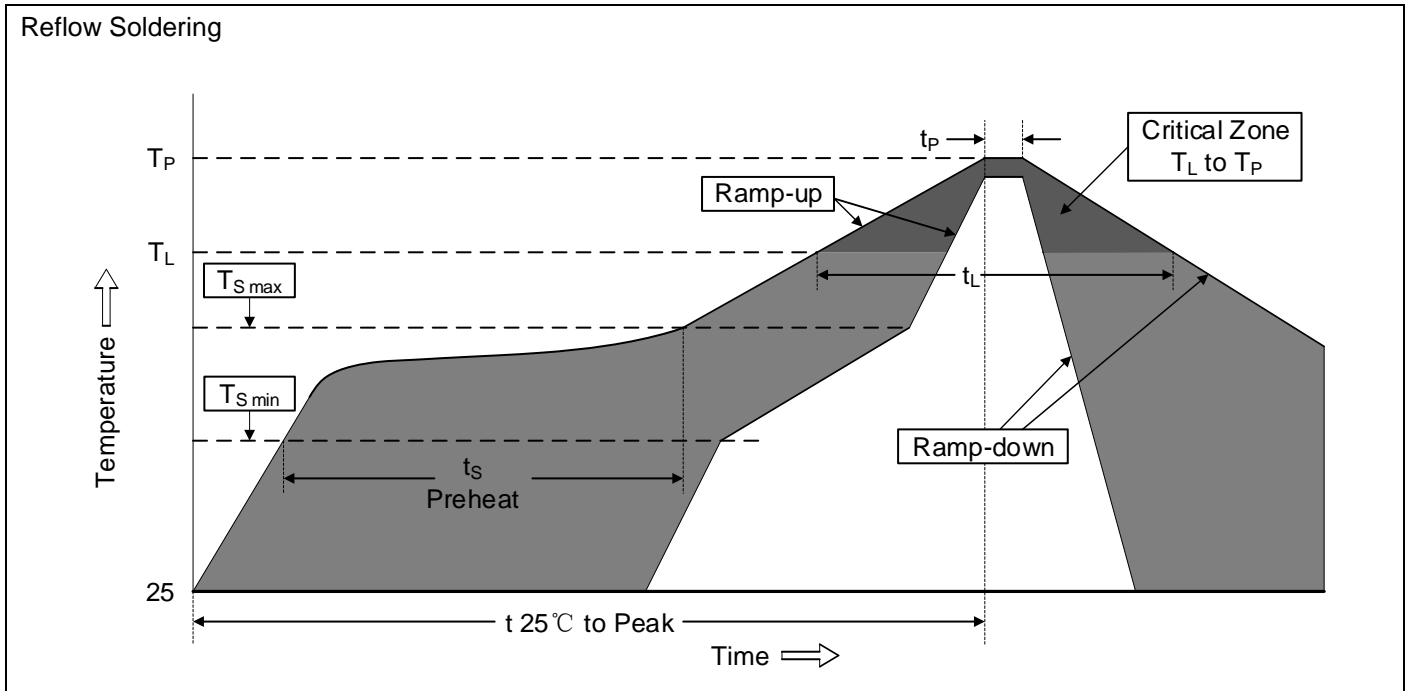

Recommended Conditions

Profile Feature	Pb-Free Assembly
Average ramp-up rate (T_L to T_P)	3°C/second max.
Preheat -Temperature Min ($T_{S\ min}$) -Temperature Max ($T_{S\ max}$) -Time (min to max) (t_s)	150°C 200°C 60-180 seconds
$T_{S\ max}$ to T_L -Ramp-up Rate	3°C/second max.
Time maintained above: -Temperature (T_L) -Time (t_L)	217°C 60-150 seconds
Peak Temperature (T_P)	260°C
Time within 5°C of actual Peak Temperature (t_p)	20-40 seconds
Ramp-down Rate	6°C/second max.
Time 25°C to Peak Temperature	8 minutes max.

Partnumber code

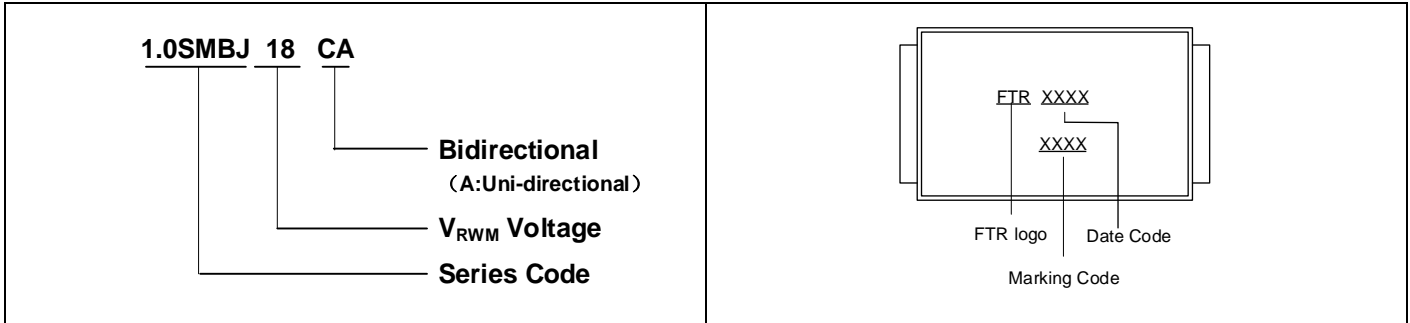

Ratings and Characteristic Curves ($T_A=25^\circ\text{C}$ unless otherwise noted)

Figure 1. Peak Pulse Power Rating Curve

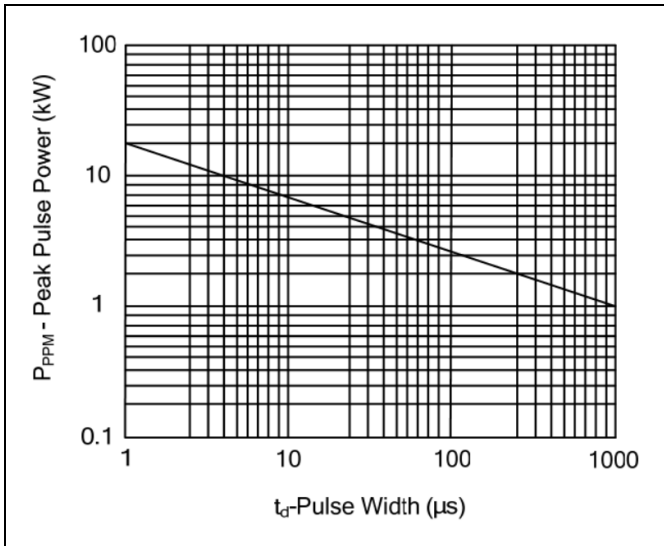

Figure 2. Pulse Derating Curve

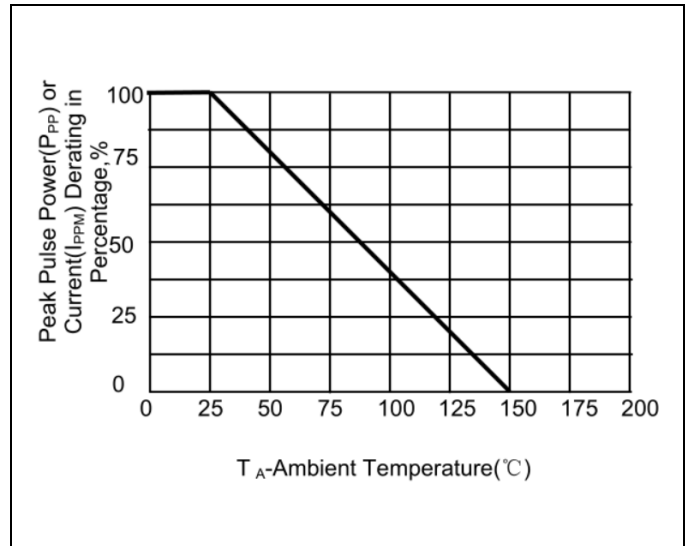

Figure 3. Pulse Waveform

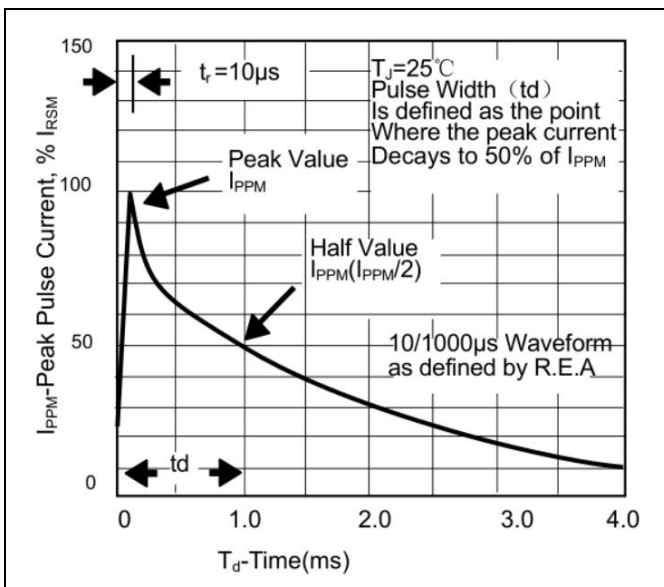
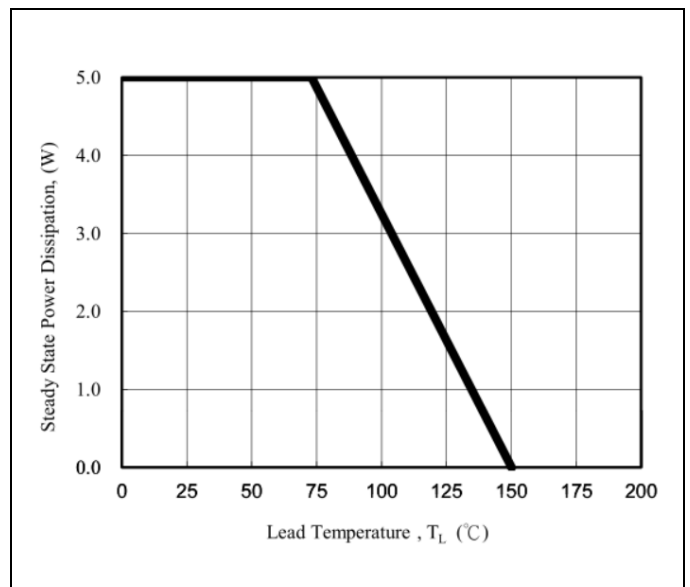
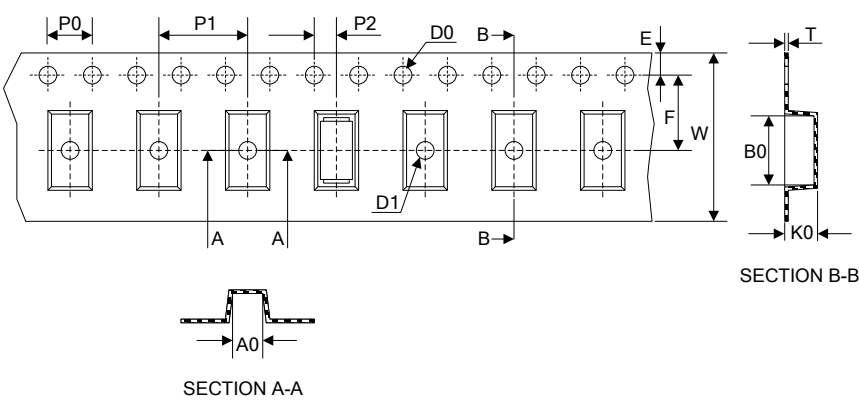
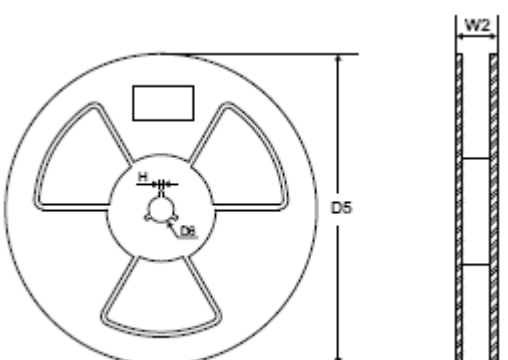

Figure 4. Steady State Power Dissipation Derating Curve



Packaging

Tape		Symbol		Dimension (mm)			
		W	12.00±0.10				
		P0	4.00±0.10				
		P1	8.00±0.10				
		P2	2.00±0.10				
		D0	Φ1.55±0.10				
		D1	Φ1.5±0.10				
		E	1.75±0.10				
		F	5.50±0.10				
		A0	3.80±0.1				
		B0	5.40±0.1				
		K0	2.45±0.1				
		T	0.25±0.1				
				D5	Φ330.0±2.0		
				D6	Φ13.5±0.5		
H	2.5±1.0						
W2	16.0±2.0						
Quantity: 3000PCS							