

Transient Voltage Suppressors (TVS) Data Sheet

Features

- Glass passivated junction
- Low zener impedance
- Excellent clamping capability
- 5000W peak pulse power capability at 10/1000µs waveform, repetition rate (duty cycle):0.01%
- Fast response time
- Typical I_R less than 1µA above 11V.
- Plastic package has underwriters laboratory flammability 94V-0
- Meets MSL level 1, per J-STD-020.

Mechanical Data

- Case: JEDEC P600Moulded plastic
- Terminal:solderplated, solderable per MIL-STD-750, Method 2026
- Polarity: Color band denotes cathode except bi-directional models
- Mounting Position: Any

Applications

- I/O interface
- AC/DC power supply
- Low frequency signal transmission line (RS232, RS485, etc.)

Maximum Ratings and Characteristics

Ratings at 25°C ambient temperature unless otherwise specified.

Rating	Symbol	Value	Units
Peak pulse power dissipation at 10/1000µs waveform (Note1, Fig.1)	P_{PPM}	Minimum 5000	Watts
Peak pulse current of at 10/1000µs waveform (Note 1, Fig.3)	I_{PPM}	See Table	Amps
Steady state power dissipation at $T_L=75^\circ\text{C}$ (Fig.4)	$P_{M(AV)}$	8	Watts
Peak forward surge current, 8.3ms single half sine-wave superimposed on rated load, (JEDEC Method) (Note2)	I_{FSM}	500	Amps
Operating junction and Storage Temperature Range.	T_J, T_{STG}	-55 to +150	°C
Typical thermal resistance junction to lead	$R_{\theta JL}$	15	°C/W
Typical thermal resistance junction to ambient	$R_{\theta JA}$	75	°C/W

Notes: 1. Non-repetitive current pulse, per Fig.3 and derated above $T_A=25^\circ\text{C}$ per Fig.2.

2. 8.3ms single half sine-wave, or equivalent square wave, duty cycle=4 pulses per minutes maximum.

	Symbol	Millimeters		Inches	
		Min.	Max.	Min.	Max.
	L	25.40	-	1.000	-
	T	8.60	9.10	0.340	0.360
	d	8.60	9.10	0.340	0.360
s	1.20	1.30	0.047	0.051	

Electrical Characteristics (TA=25°C)

Part Number		Reverse Stand-Off Voltage	Breakdown Voltage @ I_T	Test Current	Maximum Clamping Voltage @ I_{PP}	Peak Pulse Current	Reverse Leakage @ V_{RWM}
Unidirectional	Bidirectional	$V_{RWM}(V)$	$V_{BR}(V)$	$I_T(mA)$	$V_C(V)$	$I_{PP}(A)$	$I_R(\mu A)$
5KP11A	5KP11CA	11.0	12.2~13.5	5	18.2	280.2	2
5KP12A	5KP12CA	12.0	13.3~14.7	5	19.9	256.3	2
5KP13A	5KP13CA	13.0	14.4~15.9	5	21.5	237.2	2
5KP14A	5KP14CA	14.0	15.6~17.2	5	23.2	219.8	2
5KP15A	5KP15CA	15.0	16.7~18.5	5	24.4	209.0	2
5KP16A	5KP16CA	16.0	17.8~19.7	5	26.0	196.2	2
5KP17A	5KP17CA	17.0	18.9~20.9	5	27.6	184.8	2
5KP18A	5KP18CA	18.0	20.0~22.1	5	29.2	174.7	2
5KP20A	5KP20CA	20.0	22.2~24.5	5	32.4	157.4	2
5KP22A	5KP22CA	22.0	24.4~26.9	5	35.5	143.7	2
5KP24A	5KP24CA	24.0	26.7~29.5	5	38.9	131.1	2
5KP26A	5KP26CA	26.0	28.9~31.9	5	42.1	121.1	2
5KP28A	5KP28CA	28.0	31.1~34.4	5	45.4	112.3	2
5KP30A	5KP30CA	30.0	33.3~36.8	5	48.4	105.4	2
5KP33A	5KP33CA	33.0	36.7~40.6	5	53.3	95.7	2
5KP36A	5KP36CA	36.0	40.0~44.2	5	58.1	87.8	2
5KP40A	5KP40CA	40.0	44.4~49.1	5	64.5	79.1	2
5KP43A	5KP43CA	43.0	47.8~52.8	5	69.4	73.5	2
5KP45A	5KP45CA	45.0	50.0~55.3	5	72.7	70.2	2
5KP48A	5KP48CA	48.0	53.3~58.9	5	77.4	65.9	2
5KP51A	5KP51CA	51.0	56.7~62.7	5	82.4	61.9	2
5KP54A	5KP54CA	54.0	60.0~66.3	5	87.1	58.6	2
5KP58A	5KP58CA	58.0	64.4~71.2	5	93.6	54.5	2
5KP60A	5KP60CA	60.0	66.7~73.7	5	96.8	52.7	2
5KP64A	5KP64CA	64.0	71.1~78.6	5	103.0	49.5	2
5KP70A	5KP70CA	70.0	77.8~86.0	5	113.0	45.1	2
5KP75A	5KP75CA	75.0	83.3~92.1	5	121.0	42.1	2

Part Number		Reverse Stand-Off Voltage	Breakdown Voltage @IT	Test Current	Maximum Clamping Voltage @ I _{PP}	Peak Pulse Current	Reverse Leakage @ V _{RWM}
Unidirectional	Bidirectional	V _{RWM} (V)	V _{BR} (V)	I _T (mA)	V _C (V)	I _{PP} (A)	I _R (μA)
5KP78A	5KP78CA	78.0	86.7~95.8	5	126.0	40.5	2
5KP85A	5KP85CA	85.0	94.4~104	5	137.0	37.2	2
5KP90A	5KP90CA	90.0	100~111	5	146.0	34.9	2
5KP100A	5KP100CA	100.0	111~123	5	162.0	31.5	2
5KP110A	5KP110CA	110.0	122~135	5	177.0	28.8	2
5KP120A	5KP120CA	120.0	133~147	5	193.0	26.4	2
5KP130A	5KP130CA	130.0	144~159	5	209.0	24.4	2
5KP150A	5KP150CA	150.0	167~185	5	243.0	21.0	2
5KP160A	5KP160CA	160.0	178~197	5	259.0	19.7	2
5KP170A	5KP170CA	170.0	189~209	5	275.0	18.5	2
5KP180A	5KP180CA	180.0	200~221	5	292.0	17.5	2
5KP190A	5KP190CA	190.0	211~233	5	310.0	16.5	2
5KP200A	5KP200CA	200.0	222~246	5	329.2	15.5	2
5KP210A	5KP210CA	210.0	233~258	5	349.5	14.6	2
5KP220A	5KP220CA	220.0	244~270	5	371.1	13.7	2
5KP250A	5KP250CA	250.0	277~306	5	425.0	12.0	2

Notes: For bidirectional type having VRWM of 10V and less, the IR limit is double.

Recommended Soldering Conditions

Wave Soldering

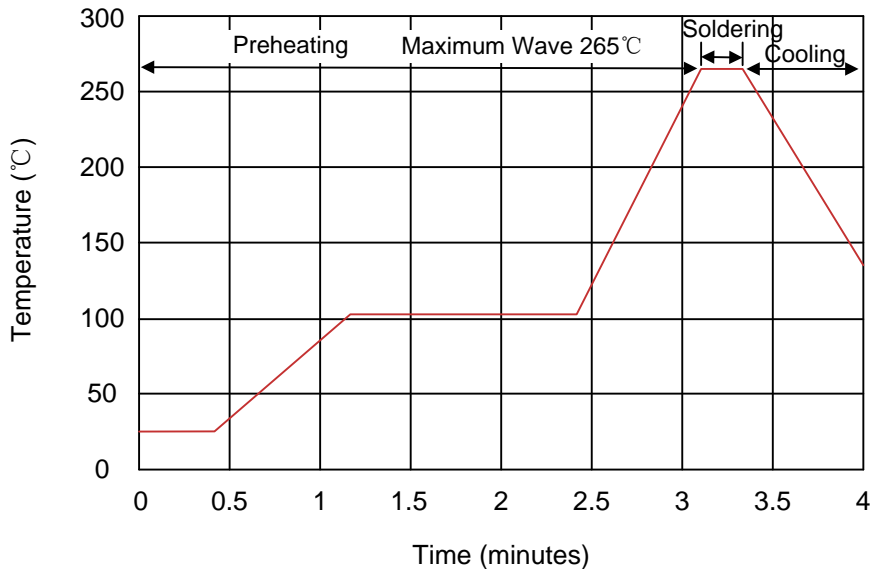

Item	Conditions
Peak Temperature	265°C
Dipping Time	10 seconds
Soldering	1 time

Partnumber code

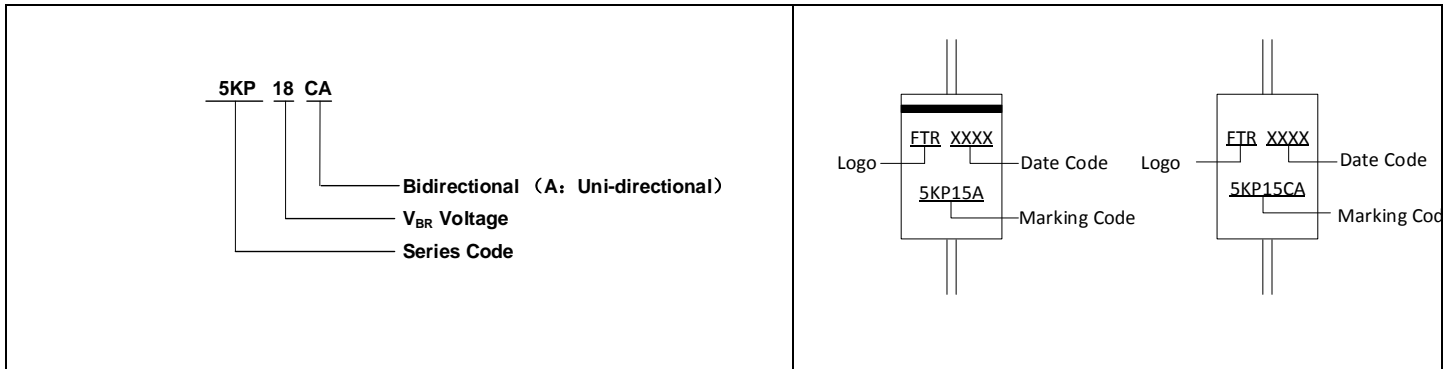

Ratings and Characteristic Curves (T_A=25°C unless otherwise noted)

Figure 1. Peak Pulse Power Rating Curve

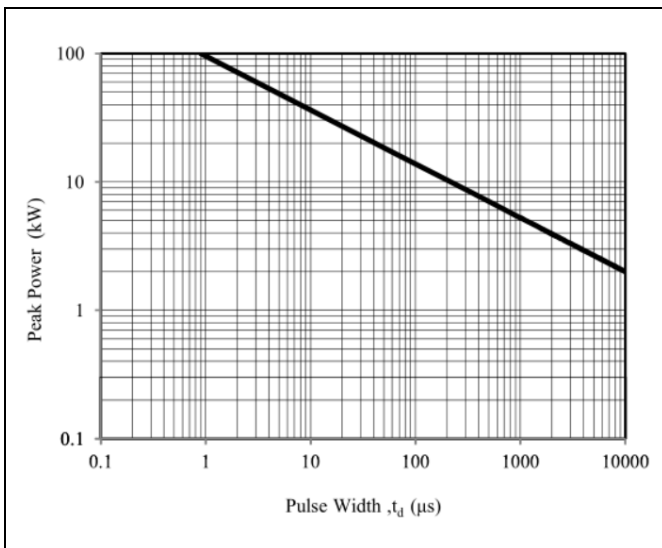

Figure 2. Pulse Derating Curve

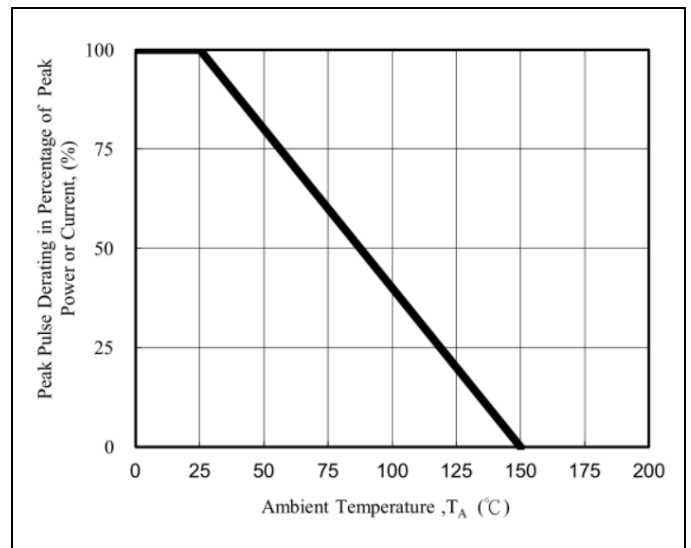

Figure 3. Pulse Waveform

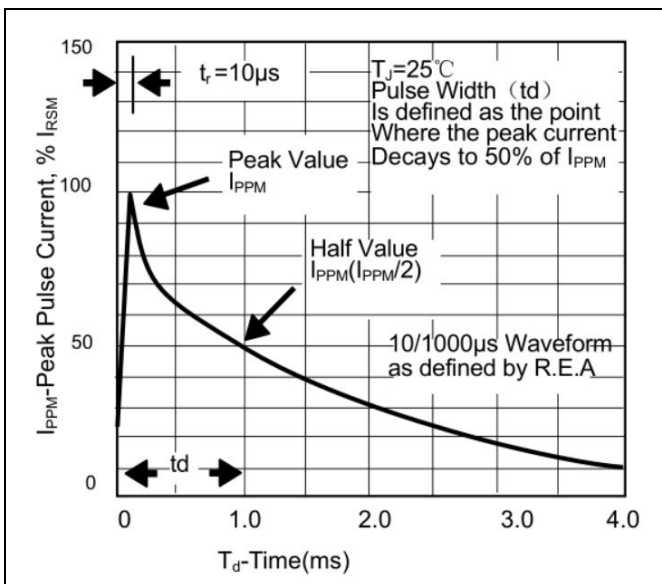
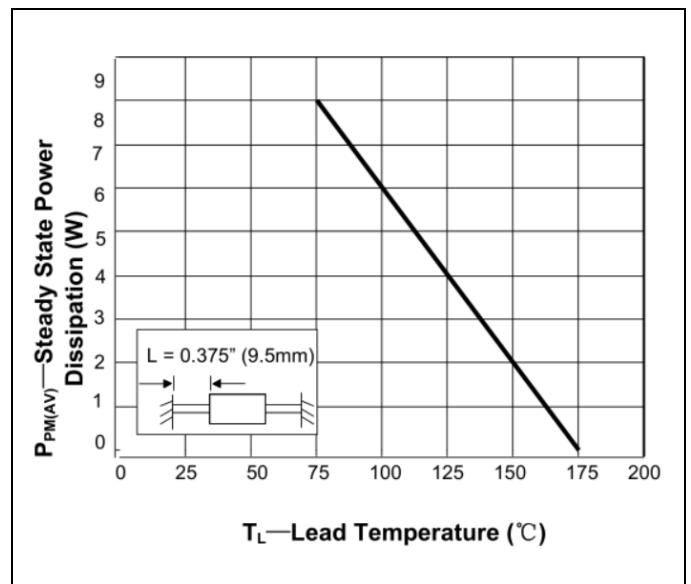
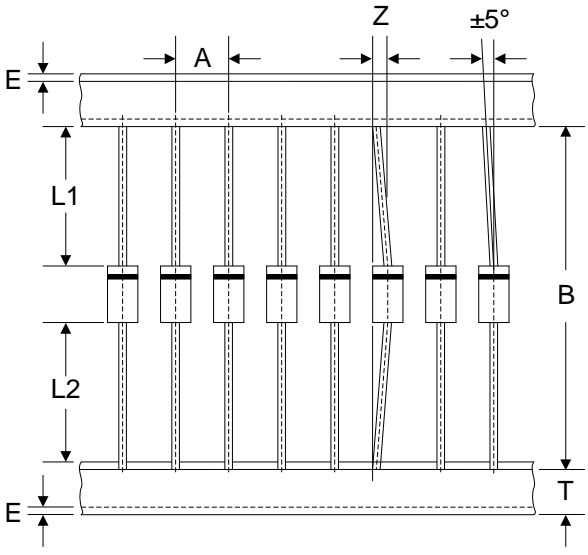
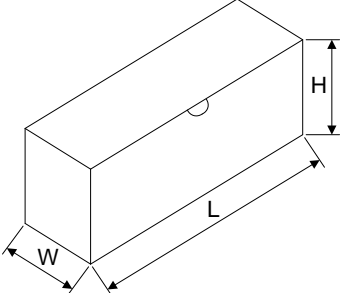

Figure 4. Steady State Power Dissipation Derating Curve



Packaging

Tape	Symbol	Dimension (mm)
	A	10.0±0.5
	B	53.0±1.0
	Z	1.2Max.
	T	6.0±0.4
	E	0.8Max.
	L1-L2	1.0Max.
		L
W		75.0±5.0
H		145.0±5.0
Quantity: 300PCS		